

## Problem J. Dome and Steles

Archaeologists recently discovered a dome built by an ancient civilization. Its inner surface was a perfect hemisphere, and many steles were stored under the dome. Those steles are cuboids, and they all have the same thickness. They were placed vertically on the flat ground and parallel to each other, as shown in the picture below. Note that, assuming that your line of sight is parallel to the steles (viewing from the lower right of the picture), no stele is allowed to block any part of another one.

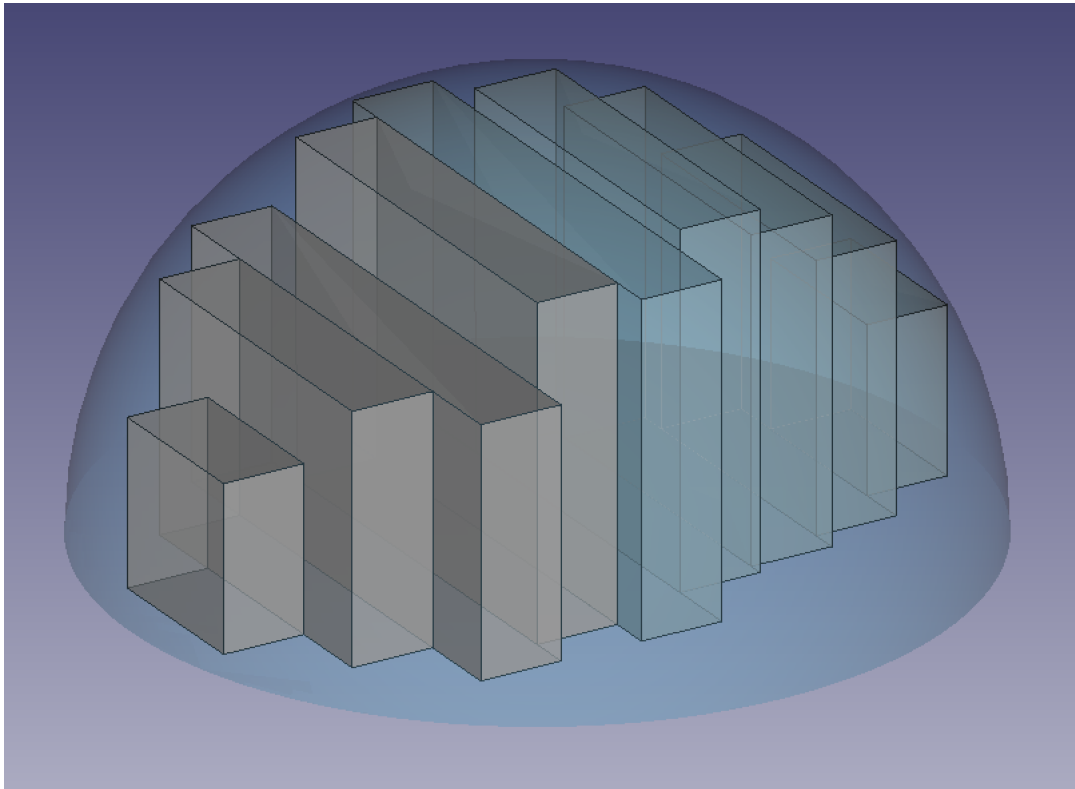

A war broke out before more information could be retrieved. The dome was completely destroyed, and the steles were scattered around. However, all the steles somehow remained undamaged, and were collected by archaeologists after the war. Now the archaeologists are planning to rebuild the dome, and they want to know the minimum radius of its inner surface.

### Input

The first line of the input gives the number of test cases,  $T$ .  $T$  test cases follow.

Each test case starts with a number  $N$ , the number of steles. Each of the next  $N$  lines contains 2 float numbers with 4 digits after the decimal point,  $a_i$  and  $b_i$ , representing two of the dimensions of stele  $i$  besides the thickness. All the steles have the same thickness, which is 1. Note that the steles and their dimensions are not in any particular order as their original placements were lost.

### Output

For each test case, output one line containing “Case # $x$ :  $y$ ”, where  $x$  is the test case number (starting from 1) and  $y$  is the minimum radius of the dome.  $y$  will be considered correct if it is within an absolute or relative error of  $10^{-6}$  of the correct answer.

## Limits

- $1 \leq T \leq 100$ .
- $1 \leq N \leq 10^5$ .
- $1 \leq a_i, b_i \leq 10^5$ .

## Sample input and output

Sample Input	Sample Output
2	Case #1: 5.0249378189
9	Case #2: 3.0000000000
2.0000 2.0000	
3.0000 4.0000	
3.0000 6.0000	
4.0000 5.0000	
4.0000 6.0000	
4.2500 4.2500	
3.8800 3.8800	
3.2200 3.2200	
2.0000 2.0000	
3	
2.0000 4.0000	
2.0000 2.0000	
4.0000 2.0000	

## Note

The first test case is illustrated in the picture above, from lower-left to upper-right.

For the second test case, note that the steles were scattered around during the war so their original placements were lost. The archaeologists only want to know the minimum inner radius.